

IC-M401E

Waterproof
1m depth for 30 minutes



Easy to See! Easy to Hear!

Large LCD (27 x 43mm)

A large LCD is incorporated into the design allowing easy viewing of the large channel display and the scrolling 10-character channel name system—even in direct sunlight, or when water has splashed on the screen. In addition, the 4-step amber backlighting for the LCD and switch illumination, allows the set to be seen in low-light conditions.



The photo shows actual display size.

Compact Front Panel

The IC-M401E has a flush mount body and compact front panel making it ideal for installation in a steering panel or bulkhead. The front panel design is well organised and contains well-labelled switches and controls providing simple operation even in the roughest weather conditions.

Waterproof Protection

The IC-M401E, including the microphone and the optional DS-100 have waterproof protection, equivalent to JIS waterproof specification grade 7*.

* 1m depth for 30 minutes; except cables.

Superior Audio with Large Speaker

The speaker's high sound pressure level delivers loud and clear reception, even over background noise. The microphone is tuned to pick up voice, while reducing ambient noise.

Optional ITU Class-D DSC Controller, DS-100

If you are really concerned about DSC operation not only for "Distress" situations, but also for private ship-to-ship calls, a clear display and functional controls are very important. The DS-100 has a 168-character display that shows full dot-matrix characters with clarity. Large, clearly labeled controls allow you to easily make routine individual, group and all ships calls. Up to 40 received messages (20 distress and 20 other calls) are stored and a total 70 address ID's (individual and Group ID) can be programmed.

And More

- Dual and tri-watch functions for monitoring Ch.16 and/or another channel, while receiving on another channel
- Supplied remote function microphone for convenient channel selection
- Up to 22 programmable channels
- Simple and easy tag scanning system
- Black or white color variations



White Color Version

SPECIFICATIONS

GENERAL

- Frequency range : Tx 156.000–161.450MHz*
Rx 156.000–163.425MHz*
* Frequency range that may be subject to licensing conditions.
- Type of emission : 16K0G3E (FM), 16K0G2B (DSC)
- Usable channels : INT, USA* channels
* Available depending on version
- Power supply : 13.8V DC ±15%
- Current drain (at 13.8V DC):
Tx high 5.5A max.
Max. audio 1.5A max.
- Operating temp. range: -20°C to +60°C
- Frequency stability : ±1.5kHz (-20°C to +60°C)
- Antenna connector : SO-239 (50Ω)
- Dimensions : 153(W)×67(H)×141.6(D) mm
(projections not included)
- Weight (approx.) : 950g

TRANSMITTER

- Output power : 25W/1W (at 13.8V DC)
- Modulation system : Variable reactance phase mod.
- Max. Freq. deviation: ±5.0kHz
- Spurious emissions : Less than 0.25µV
- Adjacent Ch. power : More than 70dB
- Residual modulation: More than 40dB

RECEIVER

- Intermediate freq. : 1st 21.7MHz
2nd 450kHz
- Sensitivity : -2dBµ emf typical
at 20dB SINAD
- Squelch sensitivity : Less than 0dBµ emf
- Intermod. rejection : More than 68dB
- Spurious response : More than 70dB
- Adj. Ch. selectivity : More than 70dB
- Audio output power : 2W at 10% distortion with a 4Ω load

Supplied accessories:

- Hand microphone
- DC power cable
- Mounting bracket kit
- Spare fuses

Measurements made in accordance with EN 301 025.
All stated specifications are subject to change without notice or obligation.

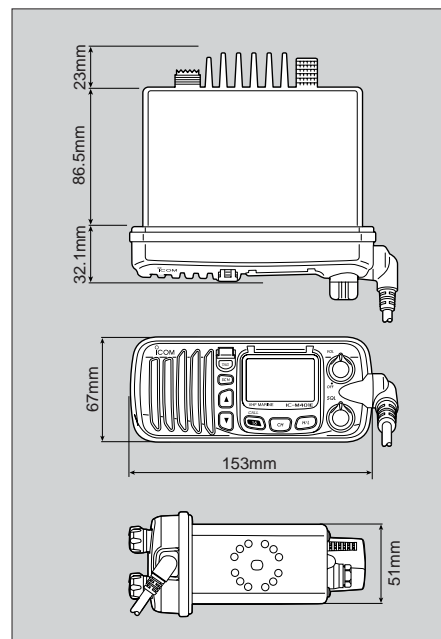

OPTIONS



DS-100

- **DS-100 DSC CONTROLLER UNIT (Ver. 02)**
- Receive frequency : 156.525MHz (Ch 70)
- Type of reception : 16K0G2B (DSC)
- Operating temp. range : -20°C to +60°C
- Antenna connector : SO-239 (50Ω)
- Dimensions (proj. not incl.): 165(W)×110(H)×84.4(D) mm
- Weight (approx.) : 1.0kg
- Sensitivity : -10dBµ typical
- Adjacent Ch. selectivity : 70dB
- Spurious response : 70dB
- Intermod. rejection ratio : 68dB
- GPS interface : NMEA0183 ver 2.0

Specifications for DS-100 are measured in accordance with EN 301 025.

- **MB-75 FLUSH MOUNT KIT**
For flush-mounting the DS-100 to a flat surface such as an instrument control panel.

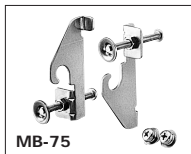

MB-75

- **MB-69 FLUSH MOUNT KIT**
For flush-mounting the IC-M401E to a flat surface such as an instrument control panel.



MB-69

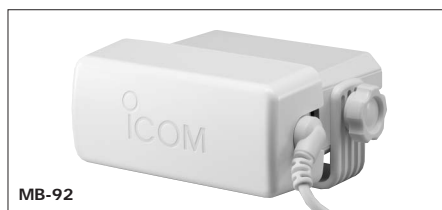

MB-92

- **MB-92 DUST COVER**
Protects the IC-M401E from dust and strong sun light when the radio is not in use. Available in white only.



SP-5

SP-10

- **SP-5 EXTERNAL SPEAKER**
A large speaker for superior audio output.
- **SP-10 EXTERNAL SPEAKER**
A compact speaker, for use in limited spaces.



Icom Inc. 1-1-32, Kamiminami, Hirano-ku, Osaka 547-0003, Japan Phone: +81 (06) 6793 5302 Fax: +81 (06) 6793 0013 URL: <http://www.icom.co.jp/world/index.html>

Count on us!

Icom America Inc.
2380 116th Avenue NE,
Bellevue, WA 98004, U.S.A.
Phone: +1 (425) 454-8155
Fax: +1 (425) 454-1509
E-mail: sales@icomamerica.com
URL: <http://www.icomamerica.com>

Icom New Zealand
146A Harris Road, East Tamaki,
Auckland, New Zealand
Phone: +64 (09) 274 4062
Fax: +64 (09) 274 4708
E-mail: inquiries@icom.co.nz
URL: <http://www.icom.co.nz>

Icom (UK) Ltd.
Unit 9, Sea St., Herne Bay,
Kent, CT6 8LD, U.K.
Phone: +44 (0)1227 741741
Fax: +44 (0)1227 741742
E-mail: info@icomuk.co.uk
URL: <http://www.icomuk.co.uk>

Asia Icom Inc.
6F No. 68, Sec. 1 Cheng-Teh Road,
Taipei, Taiwan, R.O.C.
Phone: +886 (02) 2559 1899
Fax: +886 (02) 2559 1874
E-mail: sales@asia-icom.com
URL: <http://www.asia-icom.com>

Icom Canada
Glenwood Centre #150-6165 Highway 17,
Delta, B.C., V4K 5B8, Canada
Phone: +1 (604) 952-4266
Fax: +1 (604) 952-0090
E-mail: info@icomcanada.com
URL: <http://www.icomcanada.com>

Icom (Europe) GmbH
Communication Equipment
Himmelgeister Str. 100,
D-40225 Düsseldorf, Germany
Phone: +49 (0)211 346047
Fax: +49 (0)211 333639
E-mail: info@icomeurope.com
URL: <http://www.icomeurope.com>

Icom France S.a
Zac de la Plaine, 1,
Rue Brindejonc des Moulinais BP 5804,
31505 Toulouse Cedex, France
Phone: +33 (5) 61 36 03 03
Fax: +33 (5) 61 36 03 00
E-mail: icom@icom-france.com
URL: <http://www.icom-france.com>

Beijing Icom Ltd.
10C07 Long Silver Mansion, No.88, Yong Ding
Road, Haidian District, Beijing, 100039, China
Phone: +86 (010) 5889 5391/5392/5393
Fax: +86 (010) 5889 5395
E-mail: bjicom@bjicom.com
URL: <http://www.bjicom.com>

Icom (Australia) Pty. Ltd.
A.B.N. 88 006 092 575
Unit 1 / 103 Garden Road,
Clayton VIC 3168 Australia
Phone: +61 (03) 9549 7500
Fax: +61 (03) 9549 7505
E-mail: sales@icom.net.au
URL: <http://www.icom.net.au>

Icom Spain S.L.
Crta. de Gracia a Manresa Km. 14,750
08190 Sant Cugat del Valles Barcelona, Spain
Phone: +34 (93) 590 26 70
Fax: +34 (93) 589 04 46
E-mail: icom@icomspain.com
URL: <http://www.icomspain.com>

Icom Polska
Sopot, 3 maja 54, Poland
Phone: +48 (58) 550 7135
Fax: +48 (58) 551 0484
E-mail: icompolksa@icompolksa.com.pl
URL: <http://www.icompolksa.com.pl>



Icom Inc. (Japan), is an ISO 9001 and ISO 14001 certification acquired company.

Your local distributor/dealer: